



OWNER'S MANUAL

# Motorized Trolley

## Operators Manual



# Table of Contents

1.0 Safety .....	3
2.0 Warnings .....	3
3.0 Product Introduction.....	4
4.0 Starke Motorized Trolley General Assembly Diagram.....	5
5.0 Adjusting Starke Motorized Trolley Width for the Beam Flange Width.....	6
6.0 Installing the Starke Motorized Trolley on the Beam .....	7
7.0 Part Lists and Drawings.....	8
7.1 Product Drawing.....	8
7.2 Part List .....	9
8.0 Flange Width Adders .....	15
9.0 Electrical Data.....	15
10.0 Wiring Diagrams .....	16
10.1 Early Versions .....	16
10.2 January 2024 & after.....	17
10.3 Standard Pendant Single Speed .....	18
10.4 Standard Pendant Single Speed Hoist 2-Speed Trolley .....	19
10.5 Variable Speed Pendant 1 <sup>st</sup> Step- Low Speed 2 <sup>nd</sup> Step- Variable .....	20
10.6 Variable Speed Pendant 1st Step- Low Speed 2nd Step-Variable Trolley.....	21
Starke Products Warranty.....	22

**▲IMPORTANT NOTE: Please read the below items before any operation of the unit is performed.**

## **1.0 Safety**

Because of heavy loads being moved or supported the operator and those around the area must be attentive to and aware of any risks involved with the operation of this unit. All Safety Rules must be followed, and the operator must pay attention to and abide by the warnings below and safety rules found throughout this manual.

## **2.0 Warnings**

Before operation, the operator must have a clear and unobstructed view of the whole area.

Do not attach the electrical supply wires to this unit before the completion of installation!

Before operation, inspect the work area to make sure it is safe and clear of obstructions.

While operating the trolley the operator must be careful to prevent a situation where the reverse force of changing direction causes the load to swing causing an overload of the trolley or loss of the load.

### 3.0 Product Introduction

Thank you for purchasing a Starke SMT Motorized Trolley. It is our intention that this product manual will address any concerns you may have about the operation or installation of your new trolley. This trolley comes standard as a 460V 3ph unit. Please be aware that 230V 3 phase units are available also. Make sure that the power supply you intend to hook up to this new trolley matches the voltage of the trolley you have.

All models include VFD controls with adjustable parameters for specific required low and high speeds.

**▲IMPORTANT NOTE: This Starke Motorized Trolley comes standard as a 2-Speed trolley**

This Starke Motorized Trolley comes standard as a "Lug" mount to your Starke hoist to provide you with the best hoist hook height possible. If your hoist is another brand or has a top hook you may order your trolley as a "clevis" mount which will allow you to attach a hook to the suspension shaft of the trolley.

Flange width adder kits are available for the Starke SMT Motorized Trolleys. Please consult your dealer if your beam flange is larger than the ability of your trolley. Maximum flange widths for all units = 16"



3.1 Starke STK Electric Chain Hoist on a Starke SMT Motorized Trolley

## 4.0 Starke Motorized Trolley General Assembly Diagram

4.1 Insert the suspension shaft into the Side Plate G. Attach them together with the shaft dowel pin bolt and nut.

4.2 Install some of the suspension shaft inner adjusting spacers on the shaft.

4.3 Follow (Fig 4.6) step by step installing the suspension lug into the **hoist** body first then install the trolley suspension shaft, with adjusting spacers, into the trolley Side Plate S.

4.4 Install more adjusting spacers to take up slack on the suspension shaft outside Side Plate S, then install Spacer Pin and Split Pin in hole A, (Fig 4.6)

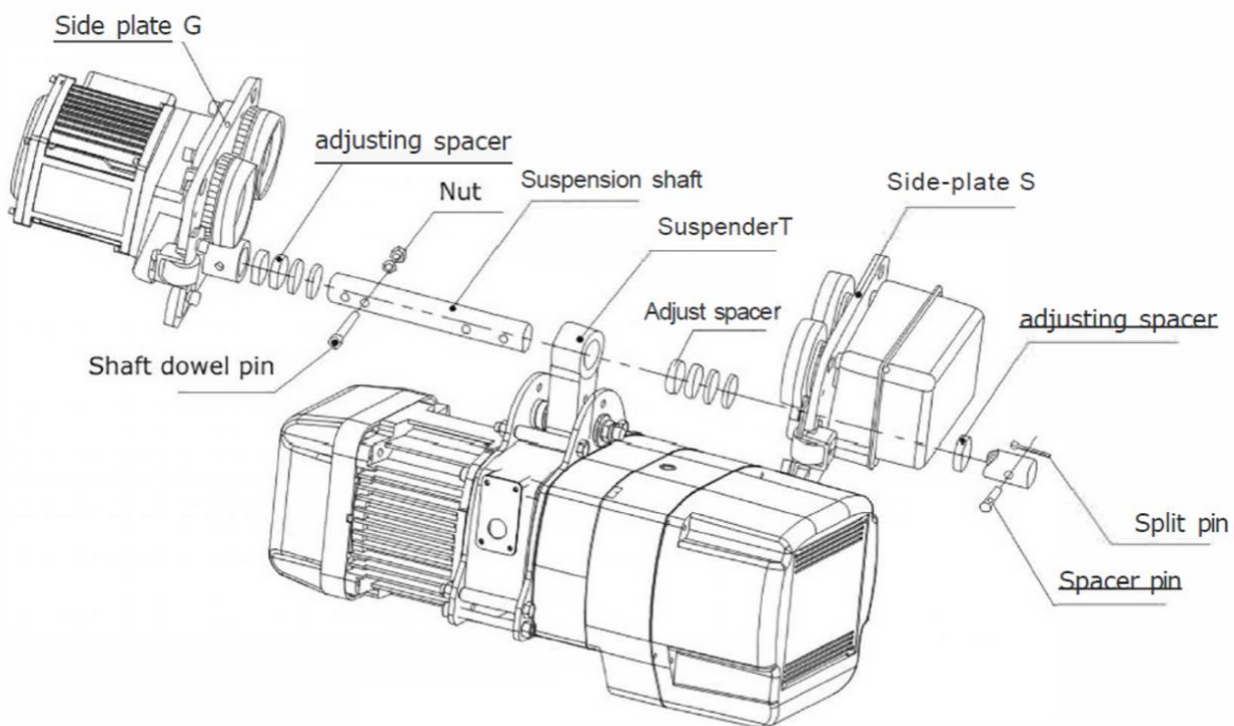

Fig 4.6

## 5.0 Adjusting Starke Motorized Trolley Width for the Beam Flange Width

5.1 Using Fig 4.7, allow 3/16" gap (as instructed below in Fig 4.7) between auxiliary side guide wheels and the beam flange so that trolley can roll freely on the beam but not be too tight or too loose.

**▲IMPORTANT NOTE: Do this before attempting to install the trolley on the I-Beam. (Do not allow more than 3/16" gap between auxiliary side guide wheels).**

5.2 To set the spacing between the trolley auxiliary side guide wheels 3/16" larger than the beam flange width, begin by installing some of the inner adjusting spacers, Fig 4.7, on the suspension shaft. (Paying attention to orientation of holes A & B as shown in Fig 4.8). Next, install the hoist lug centering the lug between the side plates G & S, Fig 4.6, as closely as possible to centerline of I-beam. Add additional inner spacers to make the 3/16" gap. (Beam flange width + 3/16" = distance between side guide wheels. Adjust with spacers accordingly and install as many of the outer spacers on the suspension shaft as possible and put the spacer pin and split pin in hole A, Fig 4.8).

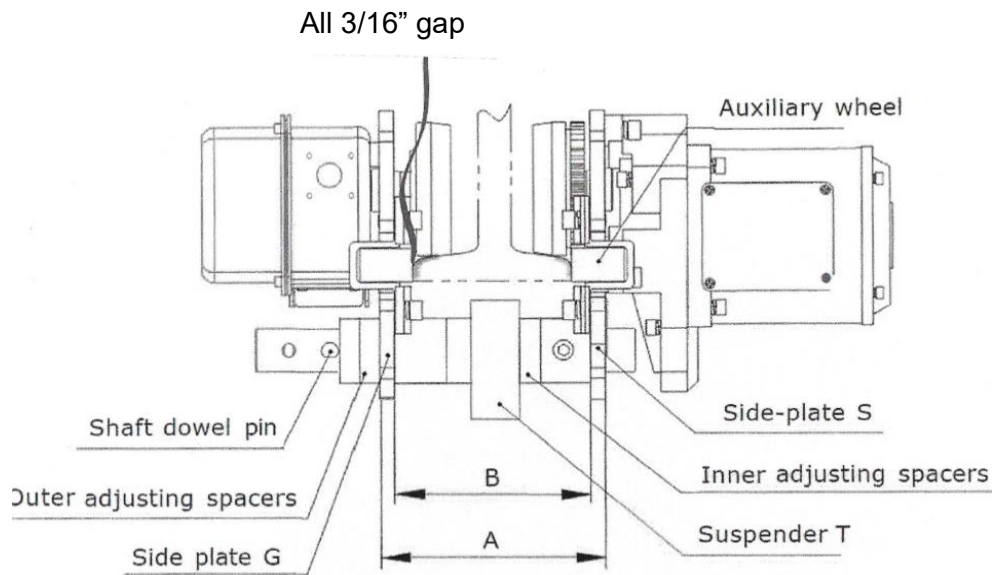

Fig 4.7

## 6.0 Installing the Starke Motorized Trolley on the Beam

### (Fits Wide Flange and S Type Beams)

6.1 Installing trolley on the beam. If possible, the assembled trolley can be installed on the end of the beam without disassembly. If this is not possible proceed to the items below.

6.2 Installing trolley on the beam. Note Position of Hole B in Fig 4.8.

6.3 Remove the spacer pin and split pin from the suspension shaft and move it to hole B in Fig 4.8

6.4 Push apart the 2 sides of the trolley to make room to raise the trolley up and put it on the beam flange.

6.5 Raise trolley up into position and set geared trolley wheels (RH side in drawing), as shown in Fig 4.6, on beam flange.

6.6 Push trolley idler wheels (LH side in drawing) onto the beam flange, as shown in Fig 4.6.

6.7 Install outside spacer pin back into hole A as in Fig 6.8 being certain you have reinstalled and spread the split pin.

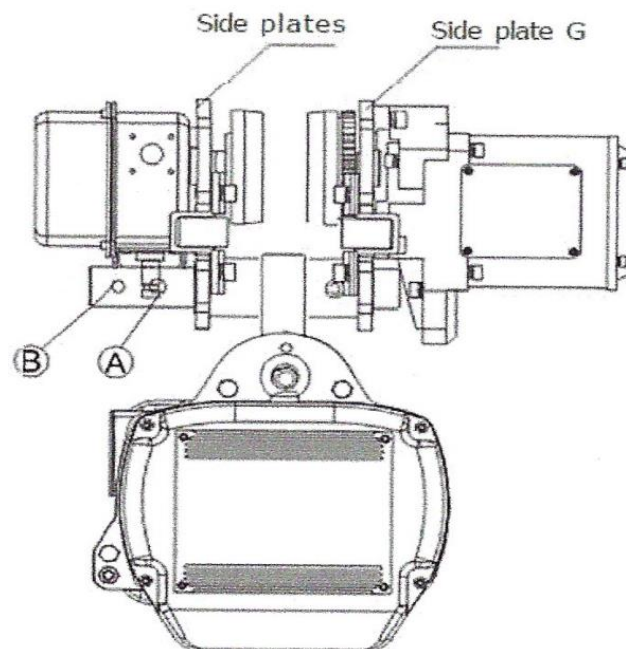
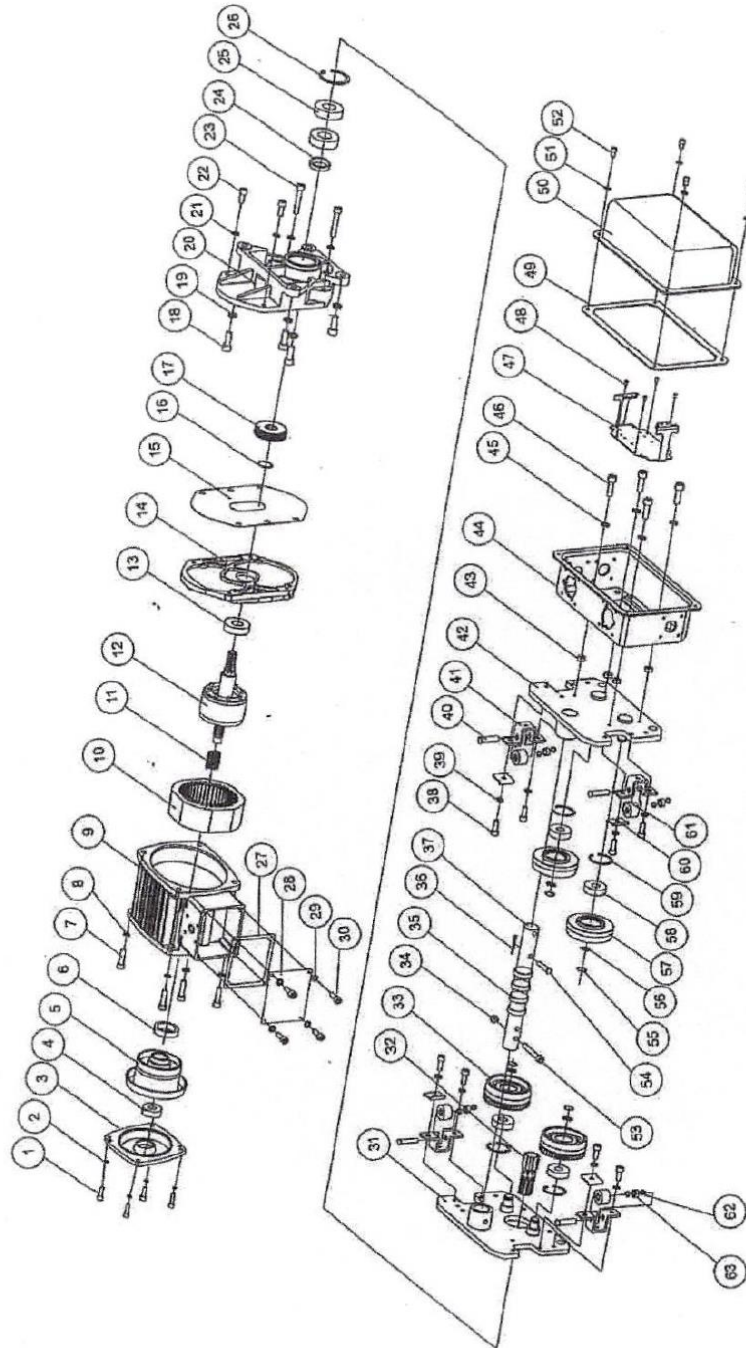

Fig 6.7

## 7.0 Part Lists and Drawings

### 7.1 Product Drawing



## 7.2 Part List

Drawing No.	Part Description	Item Number				Qty
		1 Ton	2 Ton	3 Ton	5 Ton	
1	Socket Head Cap Screw	Complete Motor Assy Includes 1-30 1 & 2 Ton Units – ½ HP = 600-46023 3 & 5 Ton Units – 1 HP = 600-46024				4
2	Lock Washer M6					4
3	Motor End Cover					1
4	Ball Bearing 6202					1
5	Brake Assy					1
6	Circlip					1
7	Socket Head Cap Screw					4
8	Lock Washer					4
9	Motor Shell					1
10	Stator					1
11	Spring					1
12	Rotor Assy					1
13	Ball Bearing					1
14	Motor Bottom Plate					1
15	Gasket					1
16	Circlip					1
17	Gear					1
18	Socket Head Cap Screw					4
19	Spring Washer					4
20	Gearbox					1
21	Spring Washer					4
22	Socket Head Cap Screw					2
23	Socket Head Cap Screw					1
24	Seal					1
25	Bearing					2
26	Snap Ring					1
27	Gasket					1
28	Side Plate					1
29	Lock Washer					4
30	Socket Head Cap Screw					4
31	Side Plate Assy	600-46051	600-46052	600-46053	600-46054	1
32	Splined Gear Shaft	600-46055	600-46056	600-46057	600-46058	1
33	Geared Drive Wheel – Incl. 58-59	600-46059	600-46060	600-46061	600-46062	2
34	Lock Nut	600-46063	600-46063	600-46063	600-46063	1
35	Spacer Kit (incl. 6 spacers, 4 washers)	600-50169	600-50170	600-50171	600-50172	8
36	Cotter Pin	600-46064	600-46064	600-46064	600-46064	1

## 7.2 Product Part List (Continued)

Drawing No.	Part Description	Item Number				Qty
		1 Ton	2 Ton	3 Ton	5 Ton	
37	Trolley Pin	600-46065	600-46066	600-46067	600-46068	1
38	Socket Head Cap Screw	600-46069	600-46069	600-46069	600-46069	8
39	Lock Washer	600-46070	600-46070	600-46070	600-46070	8
40	Auxilliary Wheel Shaft	600-46071	600-46071	600-46071	600-46071	4
41	Auxilliary Wheel Bracket	600-46072	600-46072	600-46072	600-46072	4
42	Plate	600-46073	600-46074	600-46075	600-46076	1
43	Gasket	600-46077	600-46077	600-46077	600-46077	4
44	Control Case	600-46078	600-46078	600-46078	600-46078	1
45	Lock Washer	600-46079	600-46079	600-46079	600-46079	4
46	Socket Head Cap Screw	600-46080	600-46080	600-46080	600-46080	4
47	Bracket	NSS	NSS	NSS	NSS	1
48	Screw	NSS	NSS	NSS	NSS	4
49	Gasket	600-46081	600-46081	600-46081	600-46081	1
50	Cover	600-46082	600-46082	600-46082	600-46082	1
51	Lock Washer	600-46083	600-46083	600-46083	600-46083	4
52	Socket Head Cap Screw	600-46084	600-46084	600-46084	600-46084	4
53	Socket Head Cap Screw	600-46085	600-46085	600-46085	600-46085	1
54	Pin	600-46086	600-46087	600-46088	600-46089	1
55	Circlip	600-46090	600-46091	600-46092	600-46093	4
56	Washer	600-46094	600-46095	600-46096	600-46097	4
57	Idler Wheel – Incl. 58-59	600-46098	600-46099	600-46100	600-46101	2
58	Bearing	NSS	NSS	NSS	NSS	4
59	Circlip	NSS	NSS	NSS	NSS	4
60	Retainer Bracket	600-46102	600-46102	600-46102	600-46102	4
61	Auxilliary Wheel – Incl 63	600-46103	600-46103	600-46103	600-46103	4
62	Washer	600-46104	600-46104	600-46104	600-46104	8
63	Bearing	NSS	NSS	NSS	NSS	4

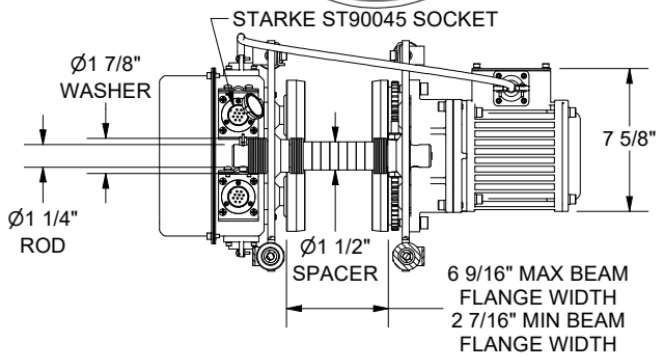
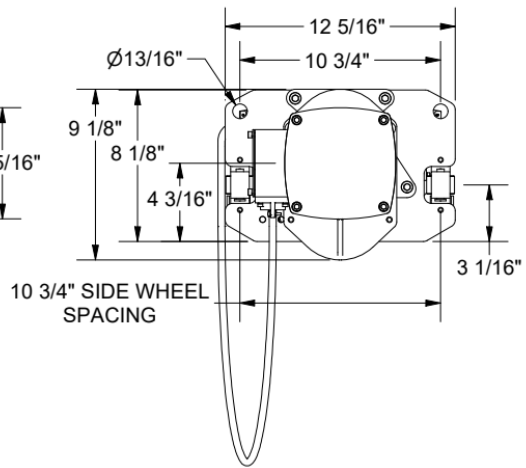
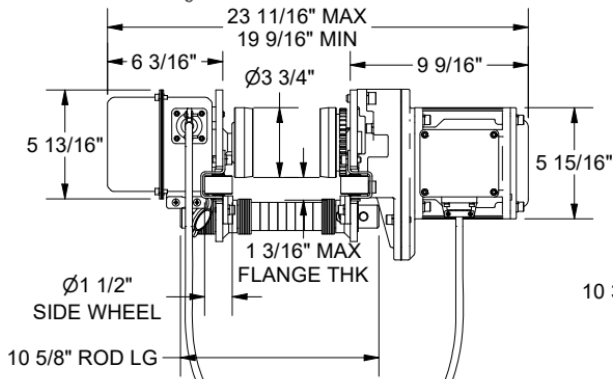
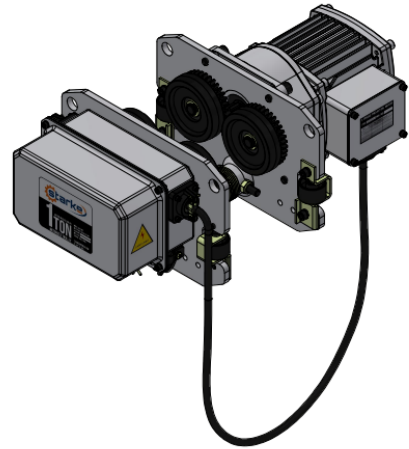
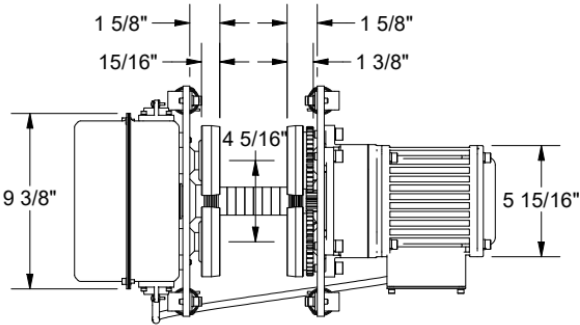

DRAWING:  
**STARKE 1-TON VARIABLE SPEED  
 MOTORIZED TROLLEY  
 SMT10VS**

TOLERANCES (U.N.O.):  
 DIMENSIONS: ±1/16"  
 ANGLES: ± 0.2°  
 MACHINING: ± 0.01"



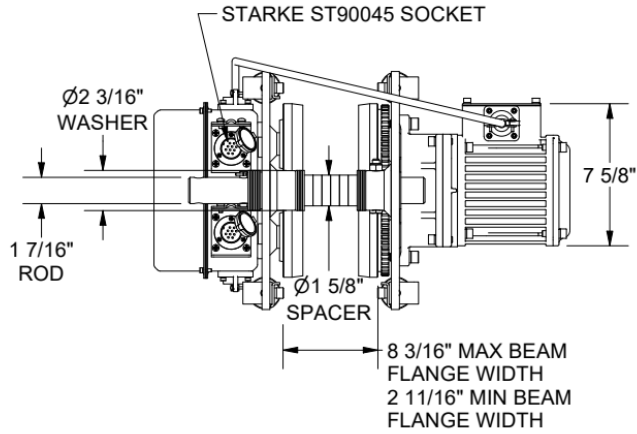
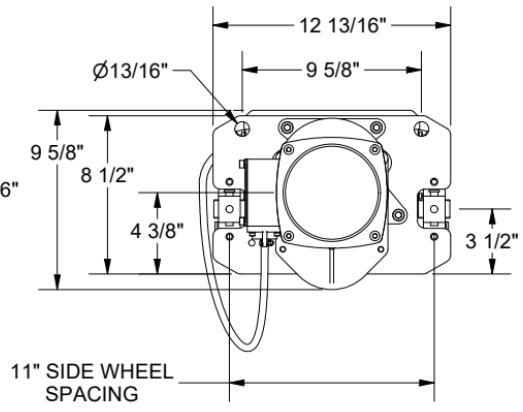
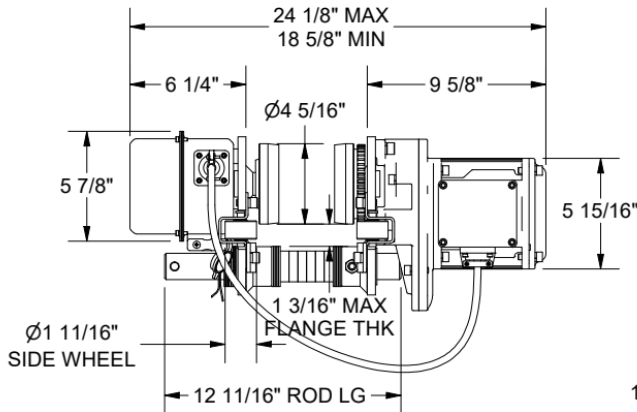
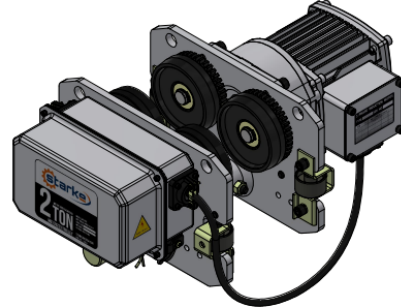
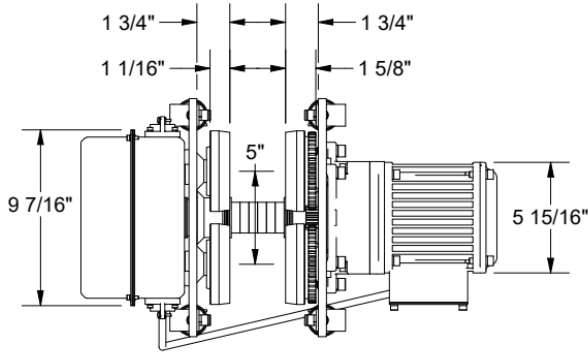

DRAWING:  
**STARKE 2-TON VARIABLE SPEED  
 MOTORIZED TROLLEY  
 SMT20VS**

TOLERANCES (U.N.O.):  
 DIMENSIONS: ±1/16"  
 ANGLES: ±0.2°  
 MACHINING: ±0.01"

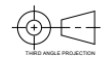

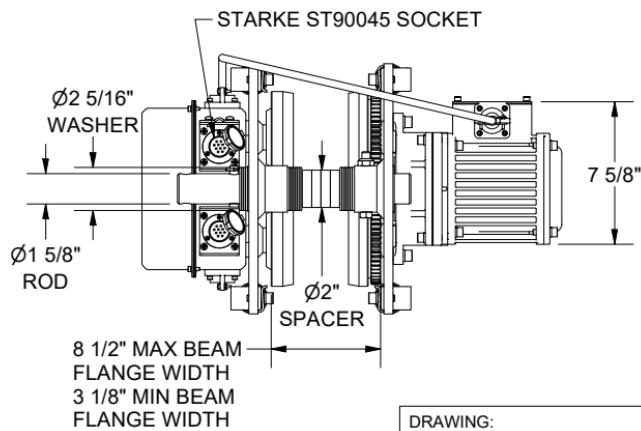
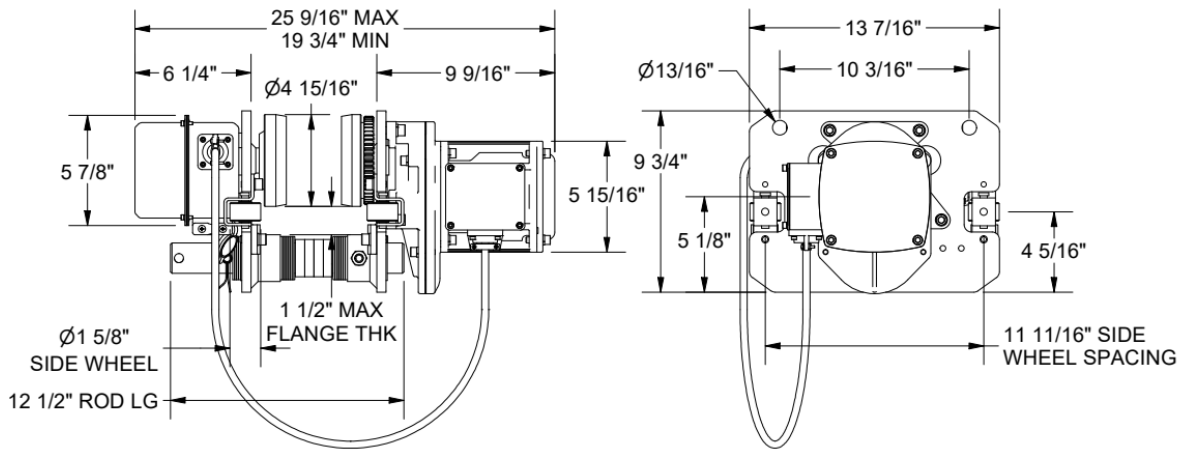
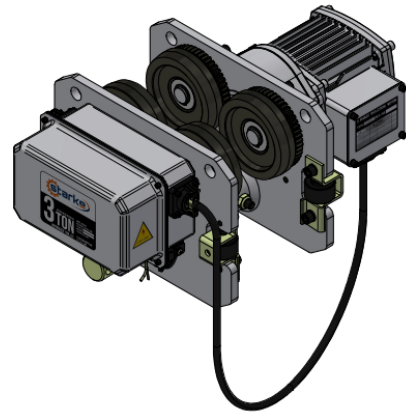
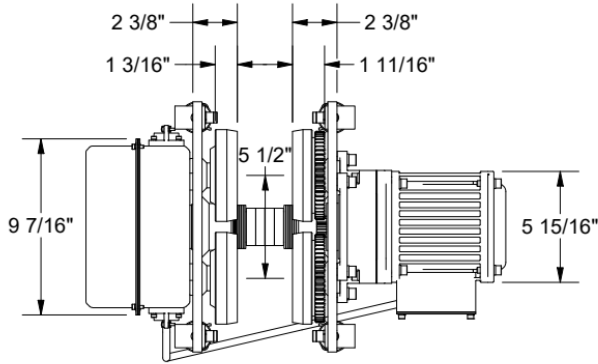

DRAWING:  
**STARKE 3-TON VARIABLE SPEED  
 MOTORIZED TROLLEY  
 SMT30VS**

TOLERANCES (U.N.O.):  
 DIMENSIONS: ±1/8"  
 ANGLES: ± 0.2°  
 MACHINING: ± 0.01"



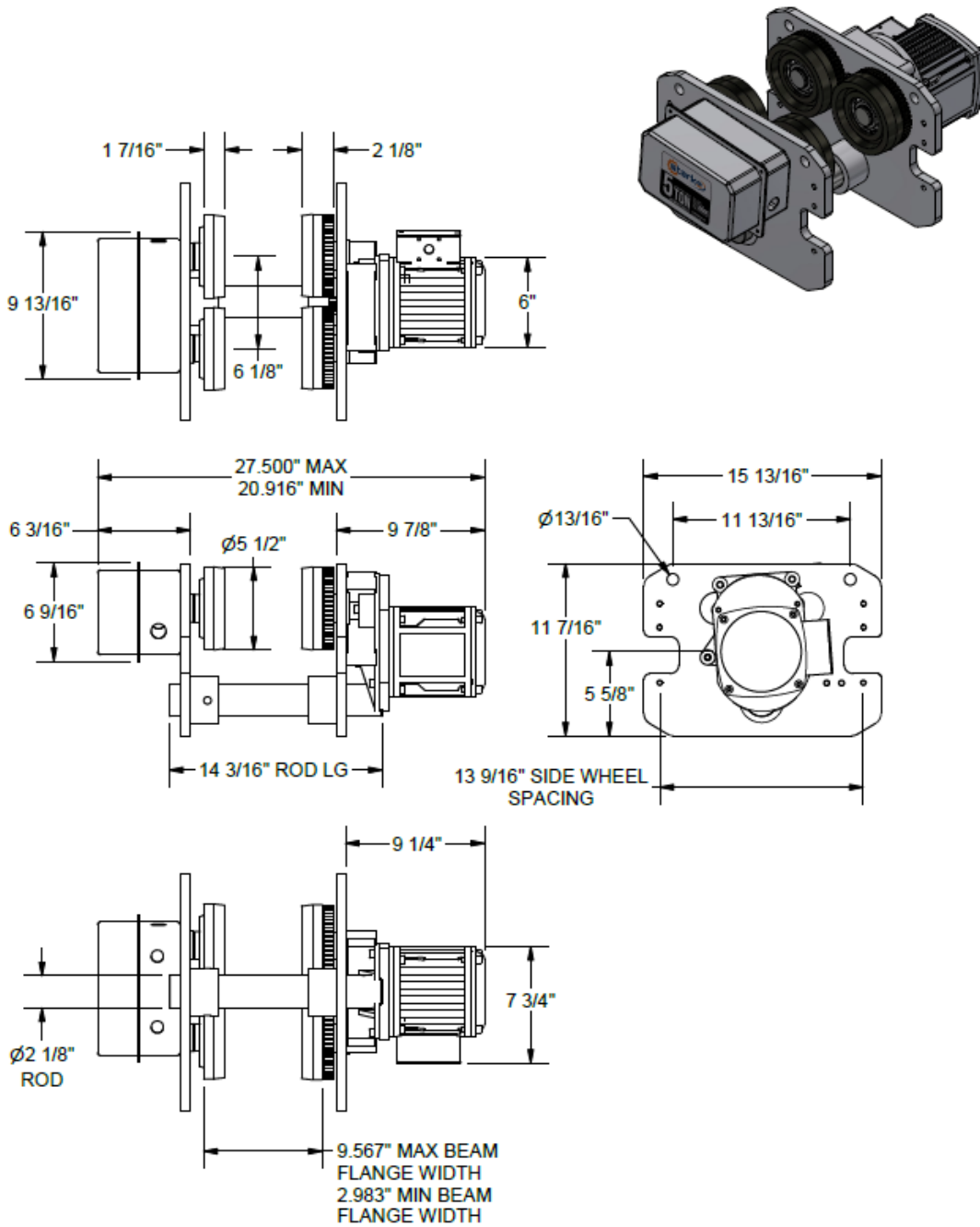

DRAWING:  
**STARKE 5-TON VARIABLE SPEED  
 MOTORIZED TROLLEY  
 SMT50VS**

TOLERANCES (U.N.O.):  
 DIMENSIONS:  $\pm 1/10''$   
 ANGLES:  $\pm 0.2^\circ$   
 MACHINING:  $\pm 0.01''$



## 8.0 Flange Width Adders

Part	Capacity	Flange Range
SMT10FW12	1 Ton	7.75" – 12"
SMT20FW12	2 Ton	9.25" – 12"
SMT30FW12	3 Ton	9.25" – 12"
SMT50FW12	5 Ton	10.87" – 12"
SMT10FW16	1 Ton	12" – 16"
SMT20FW16	2 Ton	12" – 16"
SMT30FW16	3 Ton	12" – 16"
SMT50FW16	5 Ton	12" – 16"

## 9.0 Electrical Data

Electrical Data – Motor and VFD									
Model #	Description	Standard Unit Nominal Voltage: 460/3/60 (Other Configurations Are Special Order)				Control Voltage	Brake Resistor Values	Suggested Fuse Rating (Amp)	Nominal Operating Amps
		Model Electrical Details (Danfoss VLT FC51 Equipped)							
		Motor H.P. (Nominal)	Motor kW	VFD P/N	Rated H.P. / (kW)				
SMT10VS	1 Ton VS Trolley	0.65	0.45	132F0020	2 / (1.5)	24VDC	270Ω 570w	16	1.09 ~ 1.15
SMT20VS	2 Ton VS Trolley	0.65	0.45	132F0020	2 / (1.5)	24VDC	270Ω 570w	16	1.09 ~ 1.15
SMT30VS	3 Ton VS Trolley	1	0.75	132F0020	2 / (1.5)	24VDC	270Ω 570w	16	1.09 ~ 1.15
SMT50VS	5 Ton VS Trolley	1	0.75	132F0020	2 / (1.5)	24VDC	270Ω 570w	16	1.09 ~ 1.15

For more detailed information on VFD visit this link below:

[https://files.danfoss.com/download/Drives/doc\\_MG02B622.pdf](https://files.danfoss.com/download/Drives/doc_MG02B622.pdf)

**▲IMPORTANT NOTE:** Any alterations to VFD programming may adversely affect unit operational performance and potential safety issues. Before attempting any alterations, please contact your Starke representative.

# 10.0 Wiring Diagrams

## 10.1 Early Versions

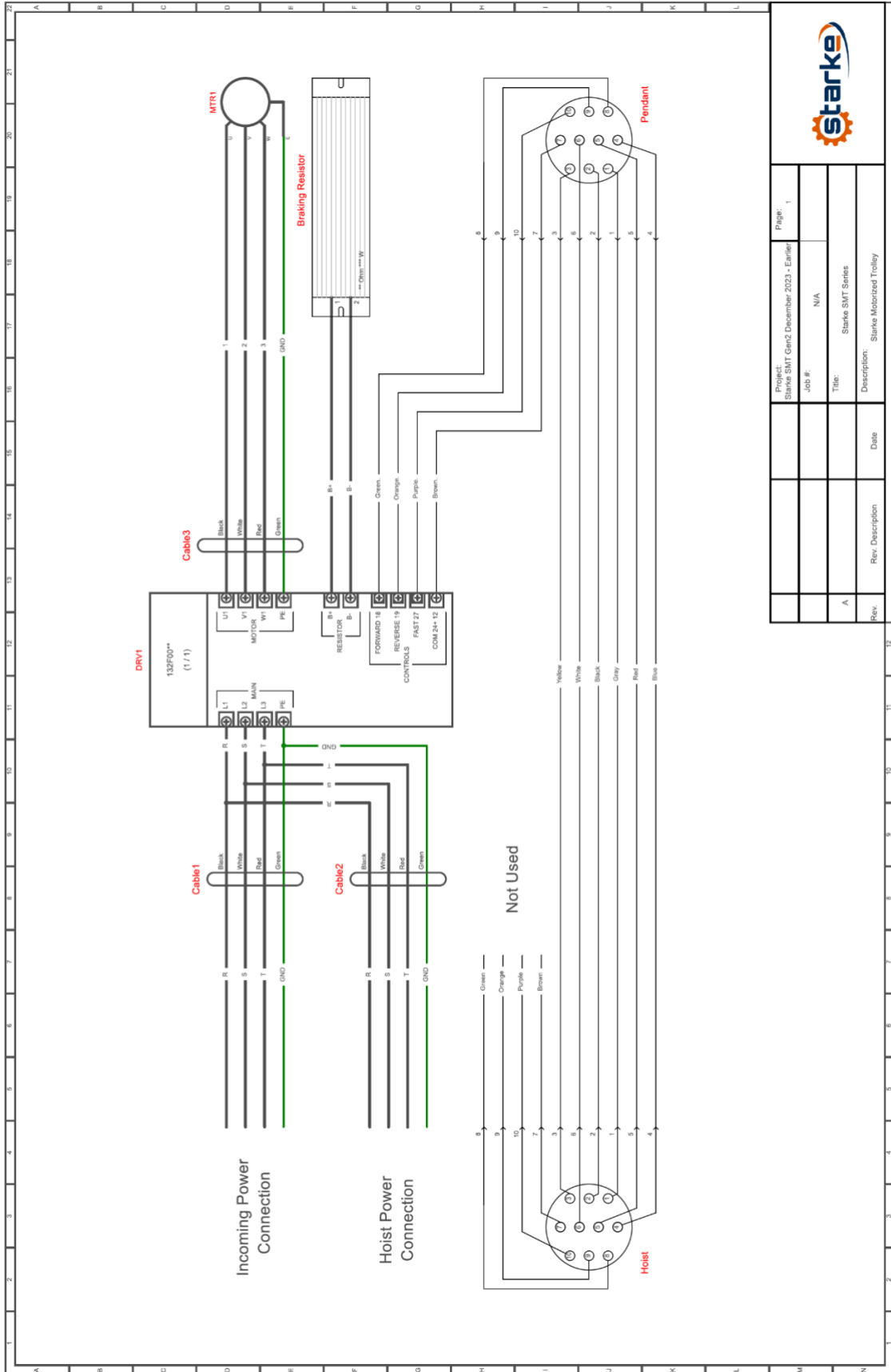

Project:	Starke SMT Gen2 December 2023 - Emiler	Page:	1
Job #:	N/A		
Title:	Starke SMT Series		
Description:	Starke Motorized Trolley		
Rev.	A	Rev. Description	Date



10.2 January 2024 &  
after

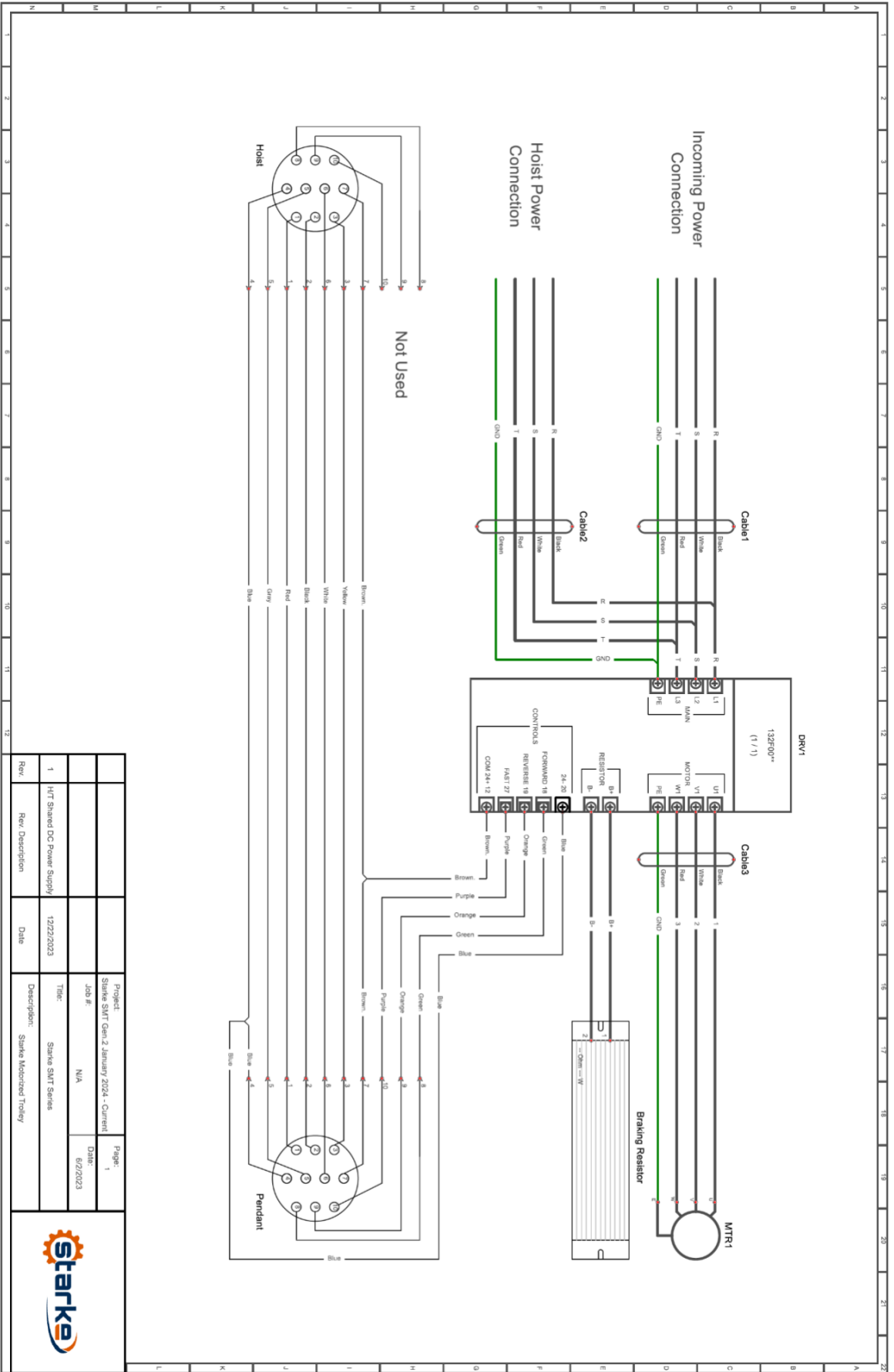

Project:	Starke SMT Gen 2 January 2024 - Current	Page:	1
Job #:	N/A	Date:	6/2/2023
Title:	Starke SMT Series		
Description:	Starke Motorized Trolley		
Rev:	Rev. Description	Date	
1	H/T Shared DC Power Supply	12/22/2023	

# 10.3 Standard Pendant Single Speed

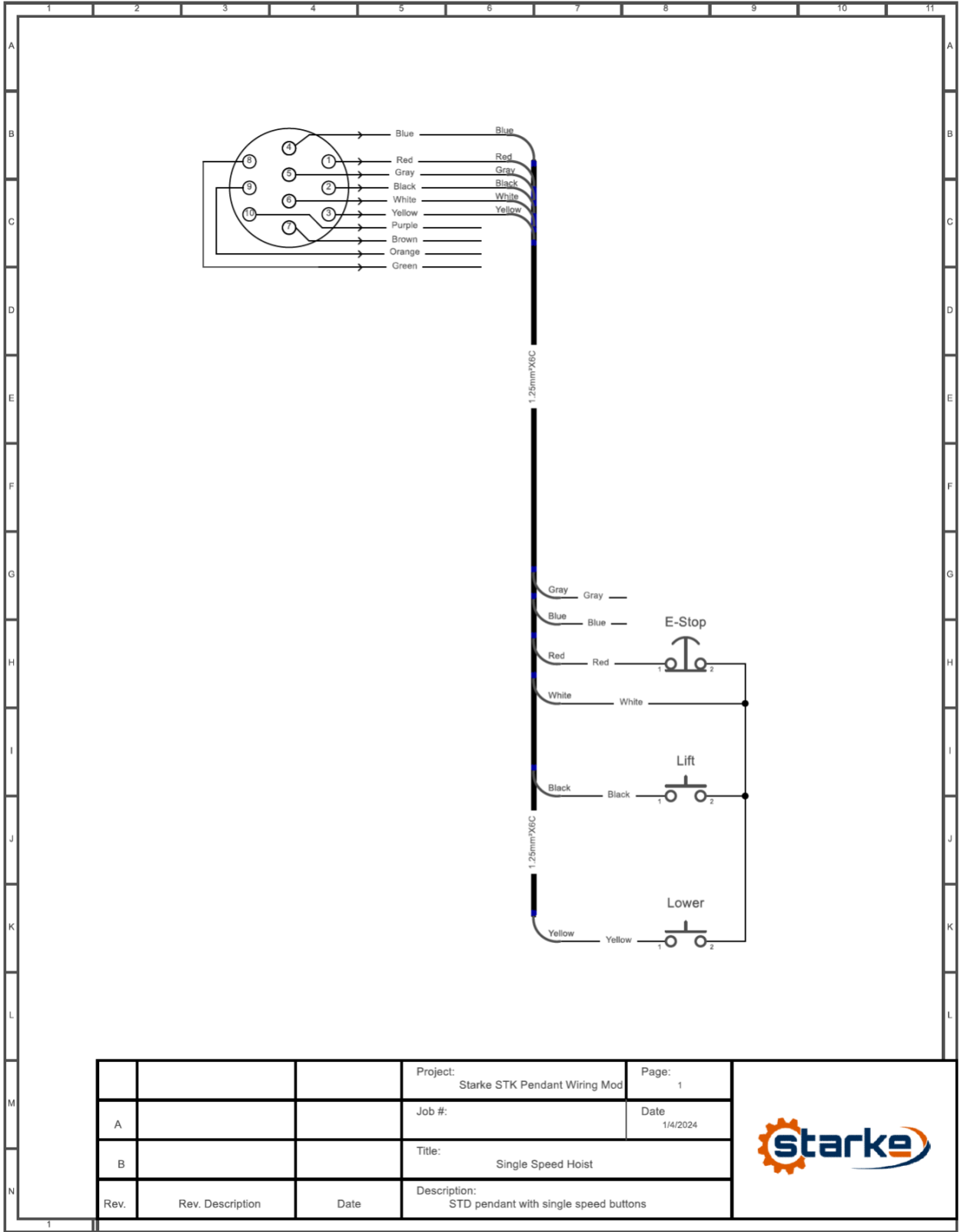

			Project: Starke STK Pendant Wiring Mod	Page: 1
A			Job #:	Date 1/4/2024
B			Title: Single Speed Hoist	
Rev.	Rev. Description	Date	Description: STD pendant with single speed buttons	



# 10.4 Standard Pendant Single Speed Hoist 2-Speed Trolley

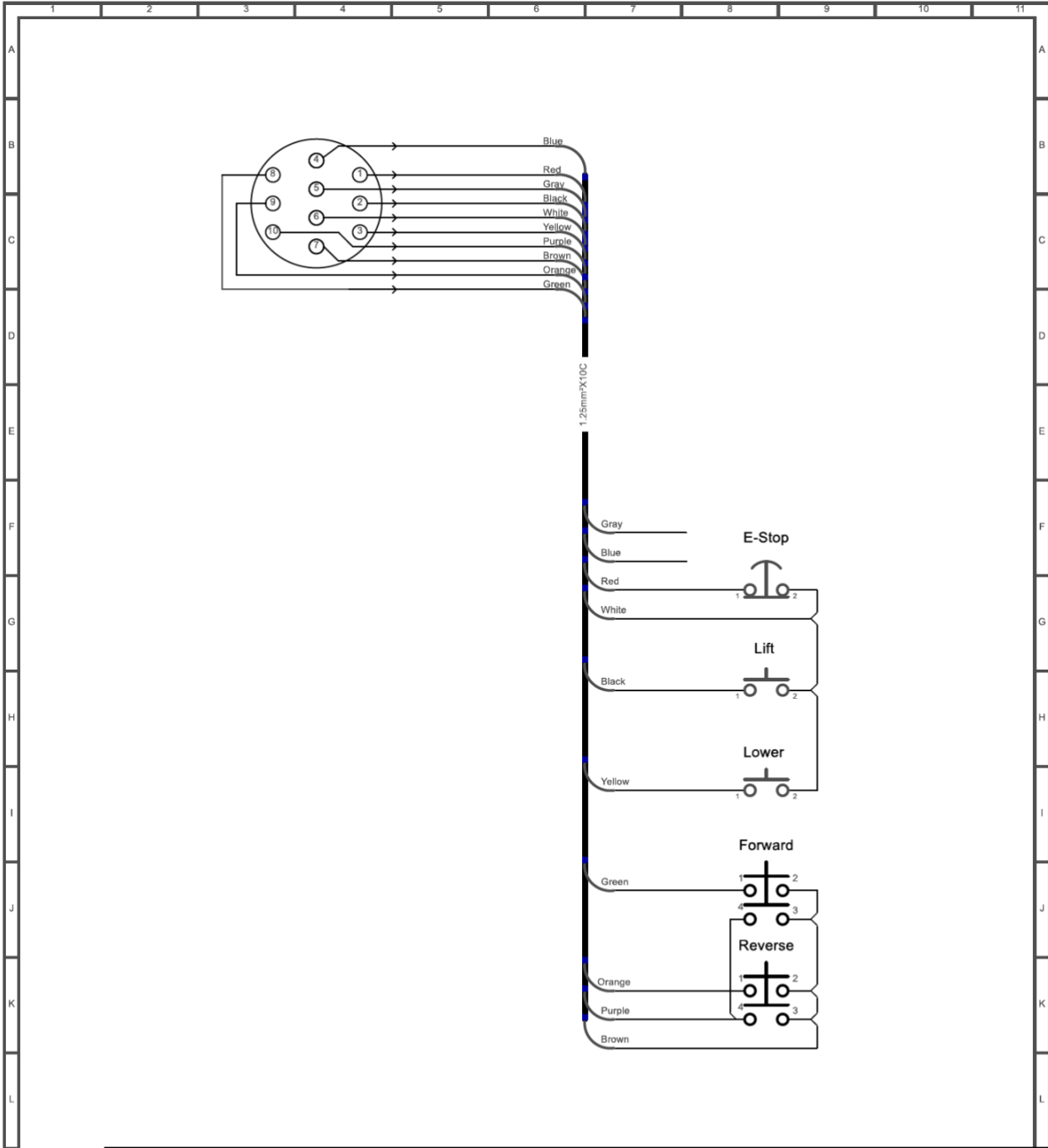

			Project: Starke STK Pendant Wiring Mod	Page: 2
A			Job #:	Date 1/4/2024
B			Title: Single Speed Hoist 2 Speed Trolley	
Rev.	Rev. Description	Date	Description: STD pendant with 2 speed buttons for Trolley	



**10.5 Variable Speed Pendant 1<sup>st</sup> Step- Low  
Speed 2<sup>nd</sup> Step- Variable**

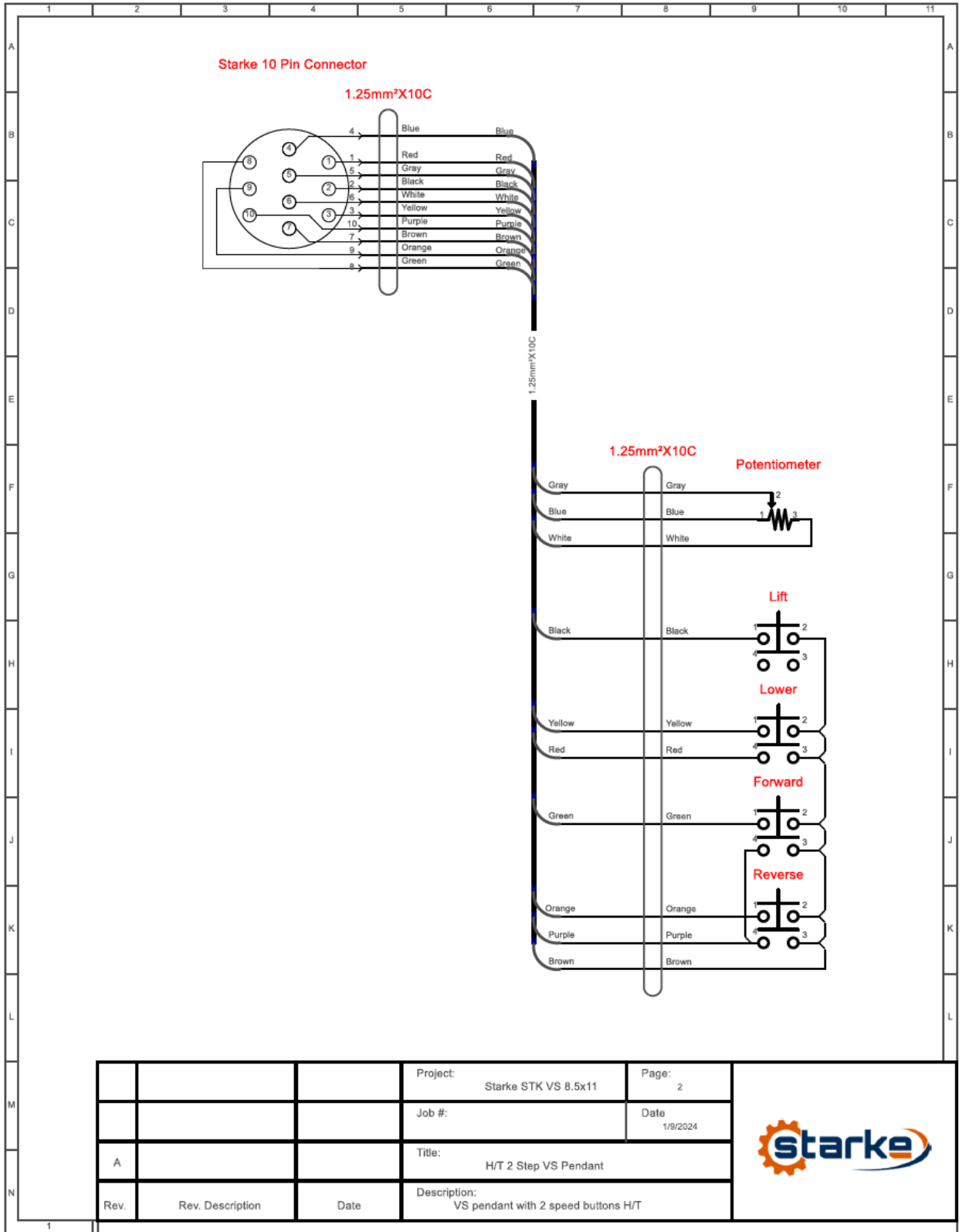

10.6 Variable Speed Pendant 1st Step- Low  
Speed 2nd Step-Variable Trolley

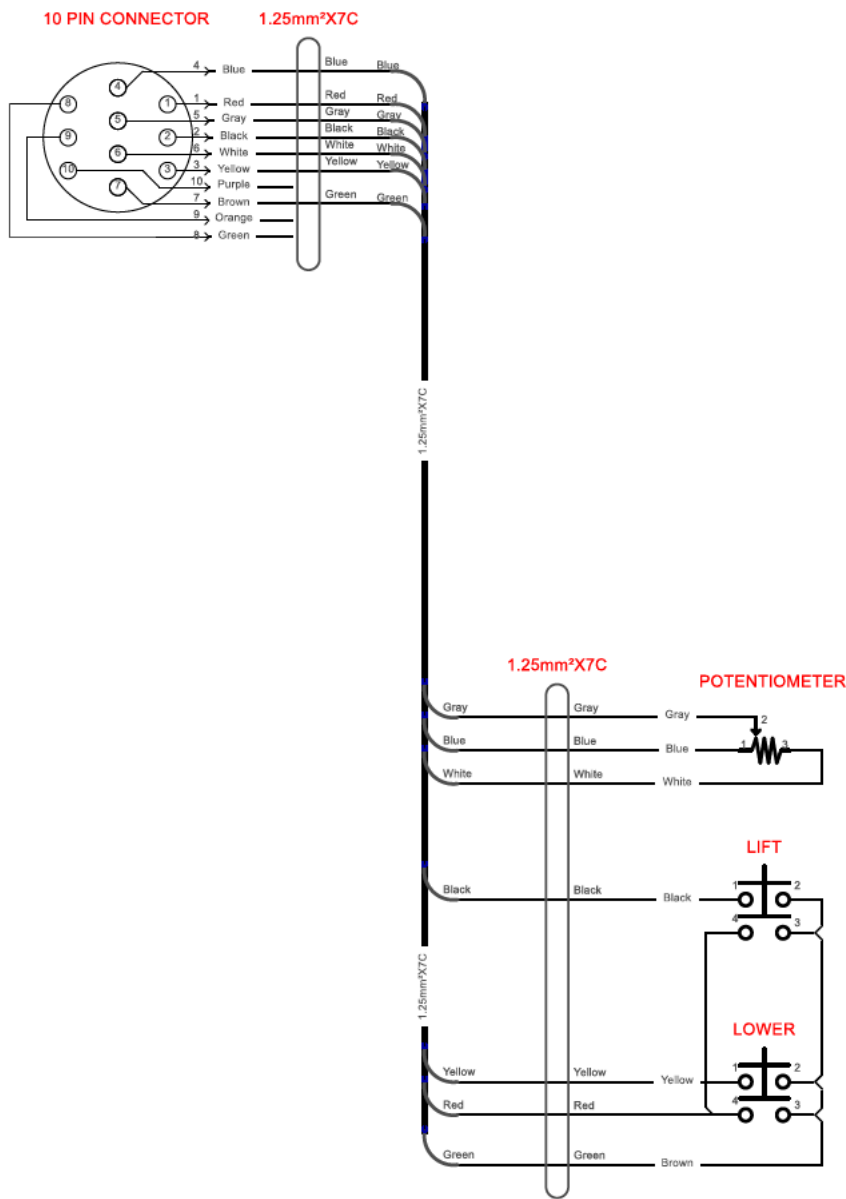

			Project: Starke STK VS 8.5x11	Page: 1
			Job #:	Date: 1/9/2024
A			Title: 2 Step VS Pendant	
Rev.	Rev. Description	Date	Description: VS pendant with 2 speed buttons	





## Starke Products Warranty

### 1 Year (12 Month) Parts & Labor Warranty

Unless otherwise specified, Starke guarantees that our products are free from material defects in design and workmanship under normal use, proper maintenance, and service.

This warranty is strictly limited to 12 months for single shift operation or 2,000 hours after installation, or 14 months after shipment, whichever is shorter. Within ten days after defect is found, warrantee must deliver a written notice to Starke providing defect information. All requested warranty information must be received promptly by Starke in no more than 5 business days.

**Customer is responsible for all shipping charges on returned/warrantable items. Starke will cover the repair (parts and labor) at no charge or provide a replacement item at Starke's discretion.**

This warranty does not cover defects or damage caused by acts of God, unusual wear and tear, improper use, or improper maintenance by the user. No responsibility for consequential damage is expressed or implied, and the responsibility under this warranty/guaranty is limited to the repair or replacement of the defective materials. Repair or replacement of the item is fully at the discretion of Starke.

*ALL OTHER REPRESENTATIONS, EXPRESS OR IMPLIED, WARRANTY, OR LIABILITY RELATING TO THE CONDITION OR USE OF THE PRODUCT ARE SPECIFICALLY DISAVOWED, AND IN NO EVENT SHALL STARKE BE LIABLE TO BUYER, OR ANY THIRD PARTY, FOR ANY DIRECT OR INDIRECT CONSEQUENTIAL OR INCIDENTAL DAMAGES*

STARKE

[Starkeamerica.com/contact-us/](http://Starkeamerica.com/contact-us/)









Contact Your Starke Representative for More Information on Products to Help Maximize Your Workplace Efficiency



**Hoists & Trolleys**



**Crane Components**



**Electrification**



**Crane Kits**



**Slings**



**Safety**

